

LAPMASTER®

MODEL 15

PRECISION OPEN FACE FLAT LAPPING MACHINE



- The Lapmaster Model 15 is a bench-mounted unit with a rigid, lightweight, cast aluminum base. The machine is of the "ring lapper" configuration, enabling high standards of flatness and surface finish to be routinely achieved.
- The Model 15 is derived from the popular Model 12 and features a scaled-up lapping plate, conditioning rings and convenient "wrap-around" worktable.
- In - process lap plate flatness control is provided for by three conditioning rings, which locate in yoke/roller bearing assemblies. Workpieces are located within carriers or appropriate fixtures which run within the rings. Large parts of cylindrical shape can be substituted for the rings.
- The Model 15 is ideally suited for lapping low and high production quantities. In-shop lapping reduces costs of component processing and equipment maintenance programs. Worn parts are reconditioned and salvaged, thus eliminating scrap. Valve bodies, discs, gears, vanes, valve plates and shaft seals are a few of the components benefiting from the lapping process.
- The Model 15 is equally at home in the laboratory, where it can be used to process a wide variety of materials on an experimental basis. These results can then be applied to a production situation.

LAPMASTER®

MODEL 15

STANDARD FEATURES

- Heavy duty cast aluminum base.
- Wrap-around worktable facilitates parts handling.
- Three conditioning rings with roller yoke and bearing assemblies to facilitate in-process plate flatness control.
- Abrasive feed system designed for water or oil based lapping slurries. Consisting of a 1/25hp/0.03 kW pump, tank and three outlet system with individual variable flow control. This permits uniform lapping rates at each work station.
- High torque drive unit with 1/2hp/0.25 kW motor and gear reducer.
- Electrical system wired for 110 volts, 60 hertz, 1 phase.
- Automatic digital cycle timer: time ranges from 0.1 to 999 seconds, minutes or hours.

STANDARD TOOLING

- High density, cast iron radially serrated lap plate 15" O.D. x 3 1/2" I.D. / 381mm O.D. x 88.9mm I.D.
- Three high density cast iron serrated conditioning rings. 7" O.D x 5 1/2" I.D. / 178mm O.D x 140mm I.D.
- Three high density cast iron pressure plates with lifting eyebolts 5 7/16" dia. x 1 1/4" thick / 138mm dia. x 32mm thick.
- 15" / 381mm hardened straight edge.
- Three micarta workholder discs 5 7/16" dia. x 1/8" thick / 138mm dia. x 3.2mm thick.
- Three felt pads 5 7/16" dia. x 1/2" thick / 138mm dia. x 13mm thick.
- Starter sample of Lapmaster abrasive.
- Starter sample of Lapmaster vehicle.
- Operation and maintenance manual.
- Allen wrench.
- Vinyl machine cover.

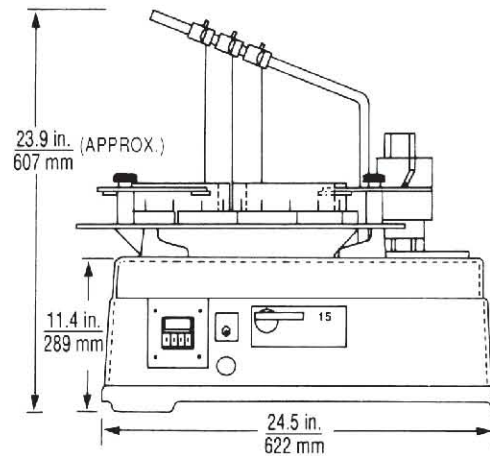
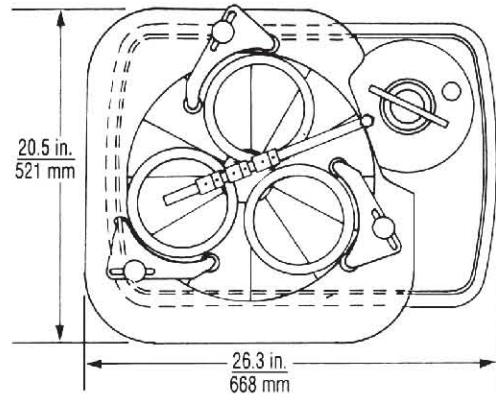

WEIGHT: 175 lbs./79.4 kg
 SHIPPING WEIGHT: 285 lbs./129 kg

AVAILABLE OPTIONS

- Soft - start (to cushion start-up).
- Electronic variable speed drive, 0-70 rpm.
- Diamond slurry dispensing systems.
- Various lapping/polishing plates.
- Non - standard voltages.
- Custom machines and tooling.



Lapmaster International
 501 West Algonquin Road
 Mount Prospect, IL 60056 U.S.A.
 telephone 224.659.7101
 fax 224.659.7103
 toll free 877.FLATNESS
 web www.lapmaster.com

Lapmaster has a policy of continued development and the specifications outlined above are subject to change without notice.