



## MODEL 24

### PRECISION OPEN FACE FLAT LAPPING MACHINE



- The Lapmaster Model 24 is the smallest floorstanding lapping machine in the range. It is equipped with a 24 inch (610mm) diameter serrated cast iron lap plate as standard. Other plates can be supplied to special order.
- The machine is constructed with a rigid welded tubular section steel frame, which supports the gearbox, drive motor and worktable, and houses both the abrasive compound feed tank and the waste tank. Access to these is provided by lift-off panels.
- The machine utilises an abrasive, such as silicon carbide, boron carbide or aluminium oxide, suspended in a suitable oil or water-based vehicle.
- As with all Lapmaster flat lapping machines, provision is made for lateral adjustment of the conditioning ring position, relative to the lap plate track, so that plate flatness can be finely controlled.
- This machine is also available in a Pneumatic Lift version. Please refer to appropriate Product Data Sheet.
- The Model 24 is ideally suited for low or high production quantities.
- The Model 24 can be used to process a wide variety of materials including semiconductors, electro-optics, ceramics, metals and other specialty products.



## MODEL 24

### STANDARD FEATURES

- Heavy duty, tubular steel, floor standing base with integrally mounted drive motor, reduction gearbox, abrasive storage, abrasive distribution system, complete with control panel.
- Heavy duty work table, vertically adjustable.
- Three conditioning rings, with adjustable roller bearing yoke assemblies to maintain lap plate flatness.
- Abrasive system, complete with pump, agitator tank and multiple point distribution.
- Electrical system wired for 230/460V 60Hz, 3 phase with operator controls at 110 V. complies with EN 60 204.
- Operator control panel with start and stop controls and multiple range, automatic cycle timer.
- High torque drive unit consisting of 1.5 kW/2 hp motor and heavy duty, sealed, maintenance-free reduction gearbox. Lap plate speed 70 r.p.m.
- Removable waste container.

### STANDARD TOOLING

- Cast iron serrated lapping plate 610mm O.D. x 114mm I.D. / 24" O.D. x 4.5" I.D. Wear life 16mm/0.6"
- Three cast iron serrated conditioning rings 286mm O.D. x 248mm I.D. / 11.25" O.D. x 9.75" I.D. Wear life 35mm/1.4"
- Three cast iron pressure plates.
- Three workholder blanks.
- Three felt pads.
- Starter sample of Lapmaster abrasive.
- Starter sample of Lapmaster vehicle.
- Lap plate lifting tool.
- Set of Allen keys.
- Operation and maintenance manual.

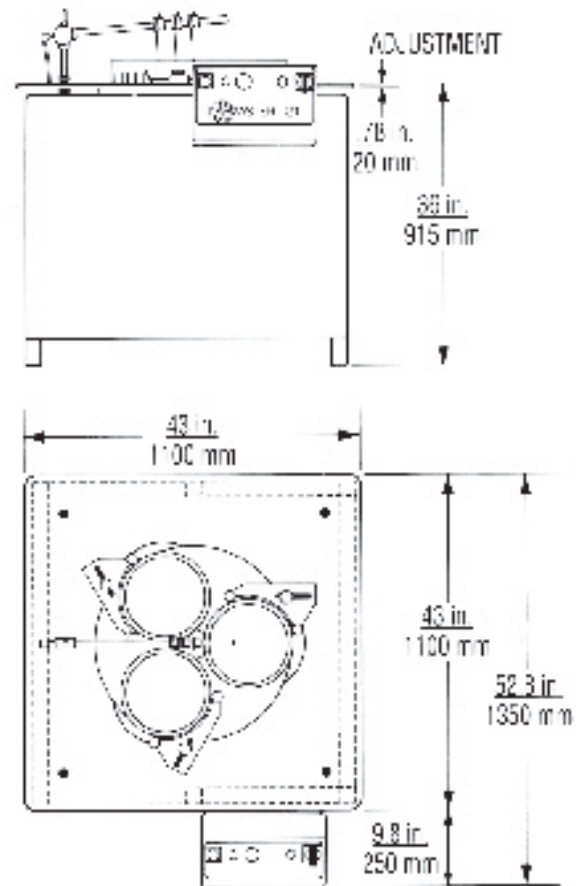

Weight: 1274 lbs/585 kg  
Shipping Weight: 1610 lbs/730 kg

### AVAILABLE OPTIONS

- 4 ring model.
- Variable speed lap drive 0-70 RPM (using frequency converter).
- Water cooled lap plates.
- Enlarged movable work table to improve multiple parts handling.
- Non-standard voltages.
- Custom machines and tooling.



Lapmaster International  
501 West Algonquin Road  
Mount Prospect, IL 60056 U.S.A.  
telephone 224.659.7101  
fax 224.659.7103  
toll free 877.FLATNESS  
web www.lapmaster.com

Lapmaster has a policy of continued development and the specifications outlined above are subject to change without notice.