



## MODEL 36

### PRECISION PNEUMATIC LIFT FLAT LAPPING MACHINE



- The pneumatic lift version of the Lapmaster Model 36 is based on the Open Face design, but the pressure weights are attached, through self-aligning bearings, to the rods of three pneumatic cylinders. These are mounted vertically on sliding rails within a fabricated hollow assembly, known as a "spider bar". This fabrication is cantilevered over the lap plate and is mounted onto a tubular upright column bolted to the machine frame. The free end is restrained by a tierod to prevent excessive bending stress when high lapping pressures are used.
- The primary function of the pneumatic arrangement is to permit loading and unloading to be carried out without the need to lift pressure weights manually. However they can be used to supply additional loading to the components within the conditioning ring should this be required.
- Operator safety is a primary concern in the design. Movement of each pressure weight up or down is controlled by a two hand anti-tie down control system. This arrangement requires the use of both hands on two separate buttons to function and ensures that the operator cannot injure his hands or arms when lowering the weights.
- A further safety feature is that the pressure weights are mechanically latched when in the fully raised position so that, should the compressed air supply or electrical power fail, they will not fall.
- The machine is intended for use with free abrasive slurries - abrasive grit suspended in an oil-based or water based vehicle. A diamond slurry dispensing system can also be fitted if required.
- Flatness of the lap plate, and consequently of the work, is controlled by adjusting the position of the three conditioning rings relative to the lap plate track. The pneumatic cylinders and pressure weights are also capable of the corresponding adjustment.
- This machine is also available in Open Face version - refer to appropriate Product Data Sheet.



## MODEL 36

### STANDARD FEATURES

- Heavy duty, tubular steel frame with integrally mounted drive motor and gear reducer.
- Heavy duty, vertically adjustable work table
- (3) Individual two hand anti-tie down pneumatic cylinder controls. Variable down pressure from 66lbs./30kg to 440lbs./200kg when connected to 60 psi minimum air supply.
- Three conditioning rings, with adjustable roller bearing yoke assemblies to maintain lap plate flatness.
- Abrasive slurry distribution system complete with pump, agitator, storage tank, waste container and multiple point feed tubes.
- Electrical system wired for 230/460 volt, 60 Hz, 3 phase with operator controls at 110 volts. NEMA Type 12 enclosure complies to JIC standards.
- Operator control panel with start/stop controls and multiple range, automatic cycle timer.
- High torque drive unit consisting of 5.0h.p./4.0kW motor and heavy duty gear reducer. Electronic soft-start included for smooth lap plate acceleration. Lap plate speed 58 rpm.

### STANDARD TOOLING

- Cast iron serrated lapping plate  
914mm O.D. x 172mm I.D/  
36" O.D. X 6.75" I.D.  
Wear life 25mm/1"
- Three cast iron serrated conditioning rings. 419mm O.D. x 368mm I.D/  
16.5" O.D. x 14.5" I.D. Wear life 70mm/2.8"
- Three workholder blanks.
- Three felt pads.
- Starter sample of Lapmaster abrasive.
- Starter sample of Lapmaster vehicle.
- Lap plate lifting tool.
- Set of Allen Keys.
- Operation and Maintenance Manual.

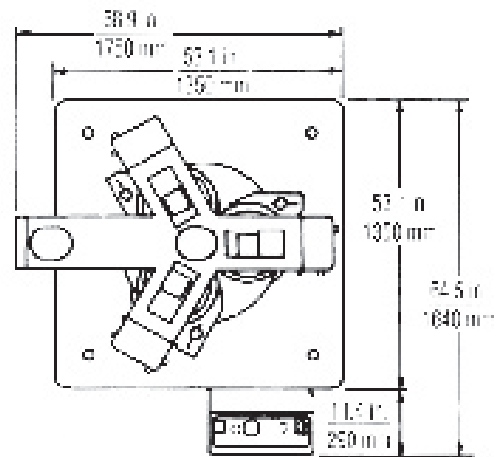
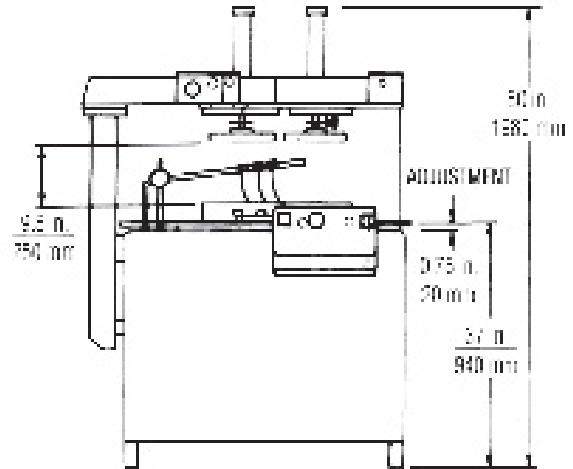

Weight: 2650 lbs / 1202 kg  
Shipping Weight: 3050 lbs / 1383 kg

### AVAILABLE OPTIONS

- 4 ring model. (I.D. 322mm/12.7")
- Water cooled lap plates.
- Machines to suit other electrical supplies.
- Custom machines and tooling.



Lapmaster International  
501 West Algonquin Road  
Mount Prospect, IL 60056 U.S.A.  
telephone 224.659.7101  
fax 224.659.7103  
toll free 877.FLATNESS  
web www.lapmaster.com

Lapmaster has a policy of continued development and the specifications outlined above are subject to change without notice.