



MODEL 56

PRECISION OPEN FACE FLAT LAPPING MACHINE



- The Lapmaster Model 56 machine is an updated version of the Model 48, with a larger diameter lap plate and support plate and correspondingly larger conditioning rings.
- The serrated lap plate is made up of twenty four individual segments which are bolted to the support plate.
- The height of the surrounding worktable can be adjusted so that it can be set just above the lap plate surface to prevent the sharp edge being exposed.
- The lap plate drive system uses a separate motor and worm and wheel reduction gearbox with multibelt drive and is mounted in a substantial floor standing base. The base is fabricated from welded hollow-section steel, clad with removable panels for maintenance. The electrical controls are housed in a console mounted at the front of the machine, and a second emergency stop button is fitted at the rear of the machine.
- The machine uses a free abrasive slurry, which is supplied from a separate free standing reservoir, equipped with a pump and driven blade stirrer. A diamond slurry dispensing system can also be fitted if required.
- This machine is also available in pneumatic lift version and as an open face machine with three special size conditioning rings.



MODEL 56

STANDARD FEATURES

- Heavy duty floor standing base, within-integrally mounted drive motor, reduction gearbox, abrasive distribution system and complete with control panel.
- Heavy duty work table, vertically adjustable.
- Four conditioning rings with adjustable roller bearing yoke assemblies to maintain lap flatness.
- Freestanding abrasive system complete with pump (0.24kW/0.3hp) driven stirrer (0.37kW/0.5hp) tank (115 litres) and multiple point distribution.
- Electrical system wired for :
220V 3 phase 50Hz
or 380V 3 phase 50Hz
or 415V 3 phase 50Hz
with operator controls at 110V.
Complies with EN 60 204.
- Operator control panel with start and stop controls and multiple range, automatic cycle timer.
- High torque drive unit consisting of 11kW/15hp motor and reduction gearbox. An electronic soft start unit is fitted as standard which smoothly accelerates the lap plate from standstill to full speed, 48rpm, over a controlled time period.
- 37 litre capacity waste container

STANDARD TOOLING

- Cast iron serrated lap plate (consisting of twenty four individual segments)
1422mm O.D. x 368mm I.D.
56" O.D. X 14.5" I.D.
Wear life 100mm/4.0".
- Four high density cast iron serrated conditioning rings
585mm O.D. x 530mm I.D.
23.0" O.D. x 20.8" I.D.
Wear life 70mm/2.8".
- Four workholder blanks
- Starter sample of Lapmaster abrasive
- Starter sample of Lapmaster lapping vehicle
- Set of Allen keys.
- Operation and maintenance manual.

NOTE: No pressure weights or felt pads are supplied normally, as for most work using this size of machine sufficient lapping load is obtained from the weight of the components themselves.

These items can be offered on request.

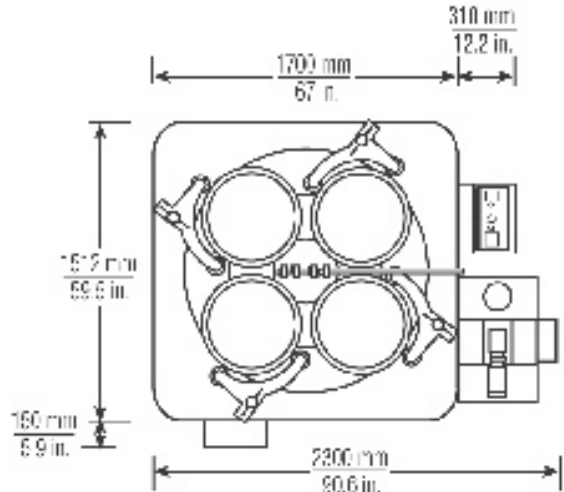
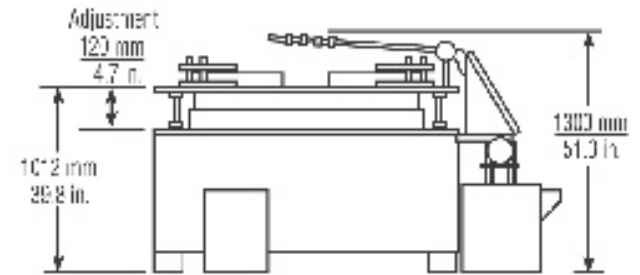

Packing Specifications:
 Weight 4750 kg/10526 lbs
 Export wooden 3 container cases
 2790 mm x 2450 mm x 2510 mm
 114 5/8" x 96 1/2" x 98 7/8"
 600 mm x 600 mm x 240 mm
 (240 mm x 240 mm x 9 3/4")
 260 mm x 800 mm x 60 mm
 (10 1/4" x 31 1/2" x 2 3/8")
 Gross weight 4465 kg/9845 lbs

AVAILABLE OPTIONS

- 3 ring model. (I.D. 578mm/22.8")
- Variable speed lap drive (using frequency inverter).
- Water cooled lap plates.
- Non-standard voltages.
- Enlarged, moveable work table to improve multiple parts handling.



Lapmaster International
 501 West Algonquin Road
 Mount Prospect, IL 60056 U.S.A.
 telephone 224.659.7101
 fax 224.659.7103
 toll free 877.FLATNESS
 web www.lapmaster.com

Lapmaster has a policy of continued development and the specifications outlined above are subject to change without notice.