



MODEL 72

PRECISION OPEN FACE FLAT LAPPING MACHINE



- The Model 72 machine is, as with all the other machines in the series, of the ring lapping type, but its design is different because of its larger size.
- Unlike the others, which have a panel clad body, the Model 72 uses a cruciform shaped structural steel base. The mechanical reduction gearbox is mounted at the centre of the base, with the drive motor to one side. Drive is transmitted via multiple vee belts, and the moving parts of the system are enclosed within a mesh guard. At the end of each arm of the cross are mounted hollow section upright columns.
- These support the trough surrounding the lap plate and provide the mounting point for each of the four roller yokes. The cast iron serrated lap plate is made up of sixteen individual segments, which are bolted to the support plate. This is a single casting which is located on a tapered cone fitted to the output shaft of the reduction gearbox.
- The drive system incorporates, as standard, an electronic soft start which will smoothly accelerate the lap plate from standstill to full speed, 36 rpm, over a controlled time period. This is a preset, though it can be adjusted if required to suit particular process conditions.
- The machine uses a free abrasive slurry, which is supplied from a separate free-standing reservoir, equipped with a pump and driven blade stirrer. Outlets are provided to feed each conditioning ring via a track wire, with individual control valves. A diamond slurry dispensing system can also be fitted if required.
- As with all ring lapping machines flatness of the lap plate can be altered by wear conditioning, that is the lateral position of the conditioning rings relative to the lap plate track can be adjusted to preferentially wear the plate's surface. For example, if the lap plate is concave then the conditioning rings are moved outboard, so that the area around the outer edge of the lap plate is worn down faster than the area near the centre, gradually improving the flatness of the plate.
- As this machine has no worktable, the roller yokes can be adjusted vertically as well as laterally, so that the normal wearing of the plate during prolonged usage can be accommodated.
- This machine is also available in Pneumatic Lift version, see Product Data Sheet.



MODEL 72

STANDARD FEATURES

- Heavy duty structural steel base, with drive motor, reduction gearbox, integrally mounted drive motor, abrasive distribution system, and complete with control panel.
- Four conditioning rings with adjustable bearing yoke assemblies to maintain lap flatness. They are also adjustable vertically to maintain constant height above the lap plate surface as it wears.
- Freestanding abrasive system complete with pump (0.28kW/0.4hp) driven stirrer (0.37kW/0.5hp) tank (115 litres) and multiple point distribution.
- Electrical system wired for : 230/460V 60Hz 3 phase with operator controls at 110V. Complies with EN 60 204.
- Operator control panel with start and stop controls and multiple range, automatic cycle timer.
- High torque drive unit consisting of 30kW/40hp motor and reduction gearbox. An electronic soft start unit is fitted as standard which smoothly accelerates the lap plate from standstill to full speed, 36 rpm, over a controlled time period.
- 37 litre capacity waste container.

STANDARD TOOLING

- Cast iron serrated lapping plate (consisting of sixteen individual segments)
1829mm O.D. x 457mm I.D/
72" O.D. X 18" I.D.
- Four cast iron serrated conditioning rings.
762mm O.D. x 692mm I.D/
30" O.D. x 27.3" I.D.
n Four workholder blanks
(3.2mm/1/8" thick).
- Starter sample of Lapmaster abrasive.
- Starter sample of Lapmaster lapping vehicle.
- Set of Allen Keys.
- Operation and Maintenance Manual.

NOTE: No pressure weights or felt pads are supplied as standard, as for most work using this size of machine sufficient lapping load is obtained from the weight of the components themselves.

These items can be offered on request.

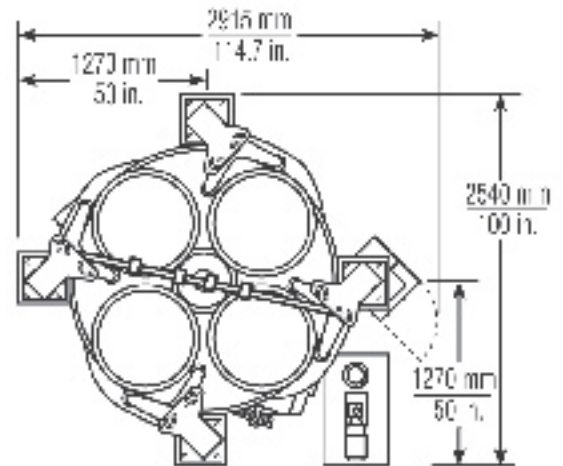
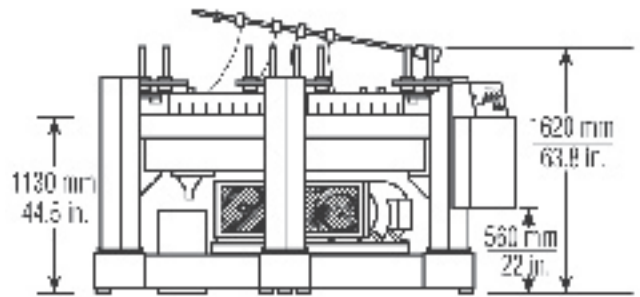

PACKING SPECIFICATIONS

Weight: 5883 Kg/12,972 lbs.
Export packed in 6 wooden cases:
2750mm x 2600mm x 2585mm
2010mm x 2010mm x 660mm
2 off 1200mm x 830mm x 445mm
790mm x 790mm x 630mm
955mm x 800mm x 860mm
Gross weight: 7846 Kg/17,300 lbs.

AVAILABLE OPTIONS

- 3 ring model.
- Variable speed lap drive (using frequency inverter).
- Water cooled lap plates.
- Non-standard voltages.



Lapmaster International
501 West Algonquin Road
Mount Prospect, IL 60056 U.S.A.
telephone 224.659.7101
fax 224.659.7103
toll free 877.FLATNESS
web www.lapmaster.com

Lapmaster has a policy of continued development and the specifications outlined above are subject to change without notice.