

# LAPMASTER®

## MODEL LSP-9

### PRECISION DUAL FACE FLAT LAPPING MACHINE



- The Lapmaster model LSP-9 is a 4-way, planetary, dual face lapping machine with a sophisticated control system. It can execute complex lapping and polishing routines while producing precise and repeatable results. The LSP machines can lap or polish a wide range of materials to very tight specifications.
- Operation is governed by a programmable controller. Custom software prompts the operator for specific operating parameters and stores up to 10 routines for recall as needed. Password protection is available to restrict access to programming or program selection.
- Through a load cell, the controller continually monitors and adjusts the top plate weight to maintain constant pressure on the parts. The LSP-9's unique combination of pneumatic pressure controls, frame design, and load control algorithms produce the most accurate and repeatable thickness results in the industry.
- The five carriers are gear driven for smooth action when lapping fragile parts. Plates and carrier speeds are varied through AC frequency inverters. The machine is built on a box beam frame and the top plate is supported from a four station bridge for stability and durability. The ring gear drops down below the plate to make loading and unloading easier.
- Vertical lifting, clear plastic guards protect the operator without getting in the way. They also keep the slurry confined to the machine, keeping the shop clean. Slurry is fed through a variable speed pump. A propeller agitator guarantees that abrasive stays suspended.
- A part thickness sizing device to automatically shut off the machine, and a water rinse at the end of each run to assist in cleaning are optional. Custom lapping and polishing plates are available upon request, as are special electrical services.
- Each machine comes complete with a set of four conditioning gears, a flatness gauge, and a starter kit of abrasive, vehicle and carriers.



## MODEL LSP-9 STANDARD FEATURES

- Programmable process controller.
- Pneumatic top plate control with load cell. Loads to 700 lbs / 300 kg.
- In-process lap plate flattening.
- Abrasive slurry distribution system with propeller type agitator, Variable speed pump.
- Transparent safety guards with machine access from three sides.
- Retractable ring gear for loading and unloading.
- Anti-vibration mounting and levelling pads.
- Standard electrical service:  
3 phase, 50 Hz, 380 or 415 volt  
3 phase, 60 Hz, 460 volt  
110 volt operator controls complies with EN 60 204.

## STANDARD TOOLING

- Two cast iron cross hatched lap plates  
630mm O.D. x 244mm I.D.  
24.8" O.D. x 9.6" I.D.
- Set of four serrated, cast iron dressing gears.
- Starter set of five blank, geared work carriers.
- Dial type, precision flatness gauge.
- Starter sample of Lapmaster abrasive.
- Starter sample of Lapmaster lapping vehicle.
- Set of Allen keys.
- Operating and maintenance manual.

## AVAILABLE OPTIONS

- Automatic thickness control.
- Rinse at end of cycle.
- Custom lap plate materials and configurations.
- Machines to suit electrical supplies.

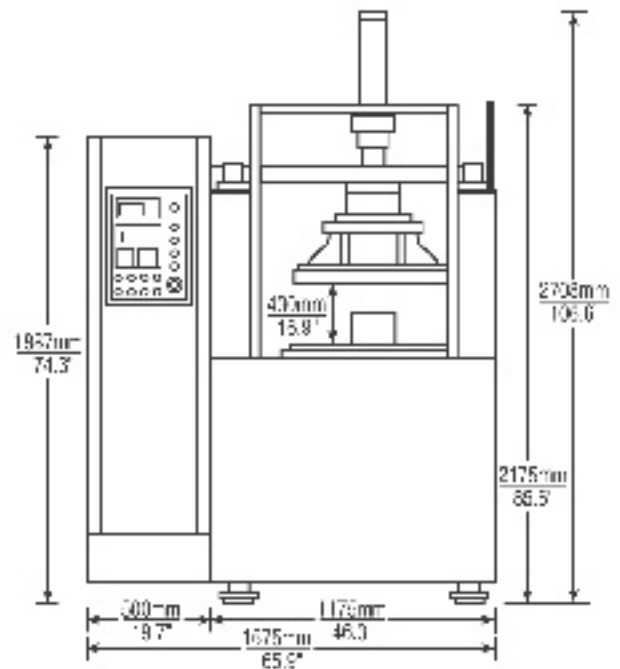
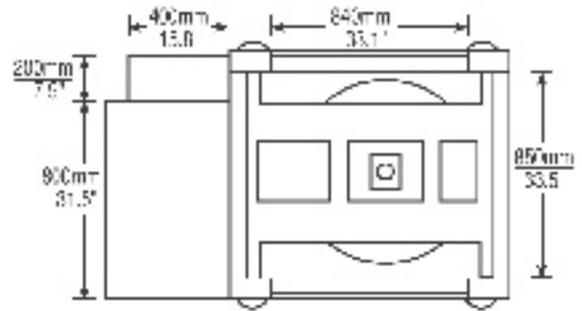

## PACKING SPECIFICATIONS

Weight: 2000kg / 4400 lbs  
 Export packed in one wooden crate:  
 1810mm x 1370 x 2540mm  
 71.26in. x 53.94in. x 100in.  
 Gross Weight: 2500kg / 5500 lbs.



Lapmaster International  
 501 West Algonquin Road  
 Mount Prospect, IL 60056 U.S.A.  
 telephone 224.659.7101  
 fax 224.659.7103  
 toll free 877.FLATNESS  
 web www.lapmaster.com

Lapmaster has a policy of continued development and the specifications outlined above are subject to change without notice.